

CONTENTS

PREFACE	ix
SECTION I. DEVELOPMENT OF AUDITORY FUNCTION	1
1. Masked and Unmasked Pure-Tone Thresholds of Infants and Adults: Development of Auditory Frequency Selectivity and Sensitivity	3
<i>Robert J. Nozza and Wesley R. Wilson</i>	
2. Pure-Tone Sensitivity of Human Infants	13
<i>Lynne Werner Olsho, Elizabeth G. Koch, Elizabeth A. Carter, Christopher F. Halpin, and Nancy B. Spetner</i>	
3. The Development of a Human Auditory Localization Response: A U-Shaped Function.	25
<i>Darwin W. Muir, Rachel K. Clifton, and Marsha G. Clarkson</i>	
4. Size of Critical Band in Infants, Children, and Adults	37
<i>Bruce A. Schneider, Barbara A. Morrongiello, and Sandra E. Trehub</i>	
5. Infant Auditory Temporal Acuity: Gap Detection	49
<i>Lynne A. Werner, G. Cameron Marean, Christopher F. Halpin, Nancy Benson Spetner, and Jay M. Gillenwater</i>	
6. Developmental Changes in Speech Discrimination in Infants	61
<i>Rebecca E. Eilers, Wesley R. Wilson, and John M. Moore</i>	
7. Linguistic Experience Alters Phonetic Perception in Infants by 6 Months of Age	71
<i>Patricia K. Kuhl, Karen A. Williams, Francisco Lacerda, Kenneth N. Stevens, and Björn Lindblom</i>	
SECTION II. BEHAVIORAL METHODOLOGY	75
Audiometric Assessment	
8. The Cross-Check Principle in Pediatric Audiometry	79
<i>James F. Jerger and Deborah Hayes</i>	
9. Response of Infants and Young Children as a Function of Auditory Stimuli and Test Methods	89
<i>Marie Thompson and Gary Thompson</i>	
10. Responses of Infants and Young Children to Behavior Observation Audiometry (BOA).	95
<i>Gary Thompson and Bruce A. Weber</i>	
11. Auditory Localization of Infants as a Function of Reinforcement Conditions	101
<i>John M. Moore, Gary Thompson, and Marie Thompson</i>	
12. Visual Reinforcement of Head-Turn Responses in Infants Under 12 Months of Age	105
<i>John M. Moore, Wesley R. Wilson, and Gary Thompson</i>	
13. Response Strength of Young Children in Operant Audiometry	111
<i>Michael A. Primus and Gary Thompson</i>	

Speech Audiometry

14. Developments in Speech Audiometry 121
Arthur Boothroyd
15. A Picture Identification Test for Hearing-Impaired Children 127
Mark Ross and Jay Lerman
16. Articulation Functions and Test-Retest Performance of Normal-Hearing Children on Three Speech Discrimination Tests: WIPI, PBK-50, and NU Auditory Test No. 6 133
Mary E. Sanderson-Leepa and William F. Rintelmann
17. The BKB (Bamford-Kowal-Bench) Sentence Lists for Partially-Hearing Children 145
John Bench, Åse Kowal, and John Bamford
18. Pediatric Speech Intelligibility Test: Performance-Intensity Characteristics 151
Susan Jerger and James Jerger

SECTION III. ELECTROPHYSIOLOGIC/PHYSIOLOGIC METHODOLOGY 163

Aural Acoustic Immittance

19. Tympanometric Detection of Middle Ear Effusion in Infants and Young Children 167
Jack L. Paradise, Clyde G. Smith, and Charles D. Bluestone
20. Tympanometric Gradient Measured from Normal Preschool Children 179
Katherine A. Koebshell and Robert H. Margolis
21. Identification of Middle Ear Dysfunction in Young Children: A Comparison of Tympanometric Screening Procedures 187
Jackson Roush, Amelia Drake, and John E. Sexton
22. Identification of Middle Ear Effusion by Aural Acoustic Admittance and Otoscopy 195
Robert J. Nozza, Charles D. Bluestone, David Kardatzke, and Ruth Bachman
23. Developmental Changes in Static Admittance and Tympanometric Width in Infants and Toddlers 211
Jackson Roush, Kristin Bryant, Martha Mundy, Susan Zeisel, and Joanne Roberts
24. Identification of Neonatal Hearing Impairment: Ear-Canal Measurements of Acoustic Admittance and Reflectance in Neonates 215
Douglas H. Keefe, Richard C. Folsom, Michael P. Gorga, Betty R. Vohr, Jay C. Bulen, and Susan J. Norton

Auditory Evoked Potential

25. Development of Auditory Function in Newborn Infants Revealed by Auditory Brainstem Potentials 235
Arnold Starr, Ragnar N. Amlie, William Hal Martin, and Stephen J. Sanders
26. Auditory Brainstem Responses from Children Three Months to Three Years of Age: Normal Patterns of Response II 243
Michael P. Gorga, Jan R. Kaminski, Kathryn L. Beauchaine, Walt Jesteadt, and Stephen T. Neely

27. Audiometric Accuracy of the Click ABR in Infants at Risk for Hearing Loss	253
<i>Martyn L. Hyde, Krista Riko, and Kathy Malizia</i>	
28. Thresholds for Auditory Brain Stem Responses to Tones in Notched Noise from Infants and Young Children with Normal Hearing or Sensorineural Hearing Loss	261
<i>David R. Stapells, Judith S. Gravel, and Brett A. Martin</i>	
29. Auditory Brain Stem Responses to Air- and Bone-Conducted Clicks in the Audiological Assessment of At-Risk Infants	275
<i>Edward Y. Yang, Andrew Stuart, George T. Mencher, Lenore S. Mencher, and Michael J. Vincer</i>	
30. Auditory Steady-State Evoked Potential in Newborns	285
<i>Field W. Rickards, Lesley E. Tan, Lawrence T. Cohen, Oriole J. Wilson, John H. Drew, and Graeme M. Clark</i>	
Evoked Otoacoustic Emissions	
31. Evoked Otoacoustic Emissions in Normal-Hearing Infants and Children: Emerging Data and Issues	295
<i>Susan J. Norton and Judith E. Widen</i>	
32. Distortion-Product and Click-Evoked Otoacoustic Emissions of Preterm and Full-Term Infants	303
<i>Jacek Smurzynski, Marjorie D. Jung, Denis Lafreniere, D.O. Kim, M. Vasudeva Kamath, Jonelle C. Rowe, Marlene C. Holman, and Gerald Leonard</i>	
SECTION IV. SCREENING FOR AUDITORY FUNCTION	
323	
33. Modeling the Cost and Performance of Early Identification Protocols	325
<i>Robert G. Turner</i>	
34. The Auditory Brain Stem Response Reliably Predicts Hearing Loss in Graduates of a Tertiary Intensive Care Nursery	335
<i>Robert Galambos, Gayle E. Hicks, and Mary Jo Wilson</i>	
35. Automated Infant Hearing Screening Using the ABR: Development and Validation	345
<i>Barbara S. Herrmann, Aaron R. Thornton, and Janet M. Joseph</i>	
36. Identification of Neonatal Hearing Impairment: Evaluation of Transient Evoked Otoacoustic Emission, Distortion Product Otoacoustic Emission, and Auditory Brain Stem Response Test Performance	355
<i>Susan J. Norton, Michael P. Gorga, Judith E. Widen, Richard C. Folsom, Yvonne Sininger, Barbara Cone-Wesson, Betty R. Vohr, Kelley Mascher, and Kristin Fletcher</i>	
37. The New York State Universal Newborn Hearing Screening Demonstration Project: Outpatient Outcome Measures	377
<i>Beth Prieve, Larry Dalzell, Abbey Berg, Mary Bradley, Anthony Cacace, Deborah Campbell, Joseph DeCristofaro, Judith Gravel, Ellen Greenberg, Steven Gross, Mark Orlando, Joaquim Pinheiro, Joan Regan, Lynn Spivak, and Frances Stevens</i>	
38. Universal Screening for Infant Hearing Impairment: Not Simple, Not Risk-Free, Not Necessarily Beneficial, and Not Presently Justified	391
<i>Fred H. Bess and Jack L. Paradise</i>	

39. Universal Screening for Infant Hearing Impairment: Replies to Bess and Paradise	399
<i>Selected Letters to the Editor</i>	
40. Universal Screening for Infant Hearing Impairment: A Reply	411
<i>Fred H. Bess and Jack L. Paradise</i>	
SECTION V. MINIMAL HEARING LOSS	419
41. Unilateral Hearing Impairment in Children	421
<i>Fred H. Bess and Anne Marie Tharpe</i>	
42. Effects of Conductive Hearing Loss: Fact or Fiction	433
<i>Ira M. Ventry</i>	
43. Hearing Acuity of Children with Otitis Media with Effusion	443
<i>Thomas J. Fria, Erdem I. Cantekin, and John A. Eichler</i>	
44. Development of Speech Intelligibility in Children with Recurrent Otitis Media	453
<i>Susan Jerger, James Jerger, Bobby R. Alford, and Sue Abrams</i>	
45. Listening and Language at 4 Years of Age: Effects of Early Otitis Media	465
<i>Judith S. Gravel and Ina F. Wallace</i>	
46. Speech Recognition in Noise by Children with Minimal Degrees of Sensorineural Hearing Loss	475
<i>Carl C. Crandell</i>	
47. Children with Minimal Sensorineural Hearing Loss: Prevalence, Educational Performance, and Functional Status	483
<i>Fred H. Bess, Jeanne Dodd-Murphy, and Robert A. Parker</i>	
INDEX Available online at www.pluralpublishing.com	

Identification of Middle Ear Dysfunction in Young Children: A Comparison of Tympanometric Screening Procedures

Jackson Roush, Ph.D.; Amelia Drake, MD; and John E. Sexton, MS

Division of Speech and Hearing Sciences (J.R., J.E.S.), and Division of Otolaryngology—Head and Neck Surgery (A.D.), University of North Carolina, Chapel Hill, North Carolina

Abstract

Two acoustic immittance screening procedures were evaluated in conjunction with pneumatic otoscopy, performed by a pediatric otolaryngologist. The subjects were 204 3- and 4-yr-old children from a rural area in eastern North Carolina. Pass-fail criteria were examined using two middle ear screening procedures: (1) a "traditional" procedure based on measures of tympanometric peak pressure and acoustic reflexes, and (2) the tympanometric measures contained within the American Speech-Language-Hearing Association's (ASHA) revised Guidelines for Screening for Hearing Impairment and Middle Ear Disorders. The traditional procedure resulted in low specificity but high sensitivity, whereas ASHA's immittance procedure resulted in high specificity but only moderate sensitivity. The negative predictive value was very high for both procedures; however, positive predictive value was low, especially for the traditional procedure. Advantages and disadvantages of the two procedures and future research needs are discussed. (*Ear Hear* 13 2:63-69)

Middle ear disorders are among the most common diseases affecting young children. Teele, Klein, and Rosner (1983) reported that over one-third of all illness-related office visits for children under the age of 5 yr involve middle ear disease. Similar findings have been reported by other investigators, including Howie (1975), who reported that two-thirds of the children seen in their pediatric practice had experienced at least one episode of otitis media by their second birthday; nearly 15% had experienced more than six episodes.

Because of the high prevalence of middle ear disease in young children and the convenience of modern tympanometric instrumentation, many educational and health care institutions now routinely conduct acoustic immittance screening of children at the preschool and early elementary grade levels. Numerous studies have examined the efficacy of acoustic immittance screening (Brooks, 1973, 1977; Cooper, Gates, Owen, & Dickson, 1974; Lous, 1983; McCandless & Thomas, 1974; Orchik & Herdman, 1974) and it is generally agreed that these measures are easy to obtain and highly sensitive to middle ear dysfunction. Unfortunately, they are considerably less accurate in identifying children without disease. That is, several investigators have reported an excessively high rate of false positive medical referrals (e.g., Lucker, 1980; Paradise & Smith, 1978; Roeser & Northern, 1988; Roush & Tait, 1985; Schow, Pederson, Nerbonne, & Boe,

1981; Wachtendorf, Lopez, Cooper, Hearne, & Gates, 1984). Consequently, many authorities now advocate immittance screening only for those children considered to be at high risk for middle ear disease (Bluestone, Fria, Arjona, et al, 1986). As noted recently by Bluestone and Klein (1990), however, referral criteria based on acoustic immittance measurements are not well established even in high risk groups, and additional research in this area is needed.

Two sets of guidelines have been widely used in recent years for immittance screening: (1) the 1979 Guidelines of the American Speech-Language-Hearing Association (ASHA) for Acoustic Immittance Screening of Middle Ear Function (ASHA, 1979), and (2) the recommendations of the Nashville Task Force, which met at Vanderbilt University in 1977 (Harford, Bess, Bluestone, & Klein, 1978). ASHA's original protocol, variations of which are still in widespread use, recommended a combination of tympanometry and acoustic reflex measures, which resulted in three possible outcomes: pass (no additional follow-up), at-risk (schedule for rescreening), or fail (medical referral). An individual was passed if the tympanometric peak pressure was between +100 and -200 mm H₂O* and an acoustic reflex was present. If a peak was identifiable but outside this range, and the acoustic reflex was present, or, if peak pressure was within this range but the acoustic reflex absent, the individual was considered to be at risk and rescreening was performed in 3 to 5 weeks, at which time the result was reclassified as either a pass or fail. Immediate medical referral was recommended if tympanometric peak pressure was outside the +100 to -200

Reprinted by permission of authors and Williams & Wilkins. Copyright 1992. *Ear & Hearing*, 13, No. 2, pp. 63-69.

range and the acoustic reflex absent, or in the event of a flat (type B) configuration.

The Nashville Task Force recommendations included similar tympanometric and acoustic reflex criteria; however, they differed from the original ASHA guidelines with respect to referral criteria. In contrast to the original ASHA protocol, which, in some cases, recommended medical referral on the basis of initial immittance findings, the Nashville guidelines recommend rescreening all individuals with abnormal tympanometric results 4 to 6 weeks after the initial test was failed. Those children who were again classified as being at risk were to be scheduled for periodic monitoring rather than medical referral.

Several studies have sought to evaluate the efficacy of immittance screening and, in general, have reported moderately high sensitivity but low specificity (e.g., Lous, 1983; Lucker, 1980; Paradise & Smith, 1978; Roeser & Northern, 1988; Roush & Tait, 1985; Wachtendorf et al, 1984). In an effort to improve the specificity of its screening guidelines and to acknowledge a new American standard for acoustic immittance instruments (ANSI, 1988), ASHA recently adopted revisions to these guidelines. ASHA's revised protocol (ASHA, 1990), summarized in Table 1, consists of four components: history, visual inspection, identification audiometry, and tympanometry. Three individual acoustic immittance measurements are contained within the new set of guidelines: static admittance, equivalent ear canal volume, and tympanometric width (gradient). As noted in the guidelines, low static admittance (peak Y) is often seen in cases of active middle ear disease, whereas abnormally large ear canal volume estimates are often observed when tympanic membrane perforations exist in the presence of normal middle ear mucosa (ASHA, 1990). An abnormally wide tympanometric gradient is often indicative of middle ear effusion. Normative data, based on the work of Margolis and Heller (1987), are published as an appendix to the Guidelines, pending a larger scale normative study.

It is important to note that the new guidelines do not include measures of tympanometric peak pressure and acoustic reflex. The revised ASHA guidelines cite evidence that these measures contribute little to the sensitivity of immittance screening while substantially lowering specificity. It should also be noted that the revised guidelines never recommend immediate medical referral on the basis of initial immittance findings alone, except in cases of abnormally large ear canal volume estimates accompanied by low static admittance (i.e., when there is reason to

Table 1. Referral criteria for ASHA's revised Guidelines for Screening for Hearing Impairment and Middle Ear Disorders (ASHA, 1990). The present study examined only the acoustic immittance component of these guidelines.

History	Otalgia Otorrhea
Visual inspection of the ear	Structural defect of the ear, head, or neck Ear canal abnormalities Blood or effusion Occlusion Inflammation Excessive cerumen, tumor, foreign material Eardrum abnormalities Obvious perforation Obvious inflammation Severe retraction
Identification audiometry	Fail air conduction screening at 20 dB HL at 1, 2, or 4 kHz in either ear
Tympanometry	Flat tympanogram with equivalent ear canal volume outside normal range Low static admittance on two successive occurrences in a 4- to 6-week interval Abnormally wide tympanometric width on two successive occurrences in a 4- to 6-week interval

suspect a perforation of the tympanic membrane). When tympanometric results are abnormal, rescreening is done after 4 to 6 weeks. If results are again abnormal, an audiological/medical referral is made. In revising the screening guidelines, the ASHA Committee has attempted to address the problems associated with previous screening protocols, as well as the need to consider advances in acoustic immittance instrumentation and standards. The present study was designed to compare the acoustic immittance portion of the revised ASHA guidelines to a more traditional middle ear screening procedure consisting of tympanometric peak pressure and acoustic reflex measures.

Method

Subjects The subjects for this study were 204 3- and 4-yr-old children enrolled in Head Start preschool programs in a rural area located in eastern North Carolina. Males and females were equally represented. Approximately 95% of the children were black, and all were from low income families.

Instrumentation Acoustic immittance data were obtained using an automatic tympanometer (Micro Audiometrics Earscan). This device uses a 226 Hz probe tone with a positive to negative pressure sweep, at a rate of 150 daPa/sec. The static value is obtained by subtracting the amplitude at +200 daPa from the peak value. The immittance measures obtained for each subject were: (1) tympanometric peak pressure, expressed in daPa; (2) ipsilateral acoustic reflex, displayed graphically on a strip chart recording; (3) equivalent ear canal volume,

*ANSI S3.39-1987 recommends the use of the international units system (SI). For air pressure, the SI unit decapascal (daPa) replaces mm H₂O, previously used for tympanometry. For practical purposes, the two units can be considered equivalent (Margolis & Shanks, 1991).

expressed in millimhos; (4) static admittance, expressed in millimhos; and (5) tympanometric width, determined manually,[†] using a template constructed for this purpose (see ASHA, 1990).

Procedures Initially, 242 subjects were seen in mid-January for acoustic immittance screening only. Six weeks later, acoustic immittance measures were repeated for all children present on the day of rescreening, including those who had normal immittance findings on the initial test. In addition, otoscopic examination, performed by a pediatric otolaryngologist, was conducted for each child.

Otosopic Examination Pneumatic otoscopy was performed on all children seen at the time of the second screening by the same physician, an otolaryngologist whose regular caseload consists primarily of pediatric patients, and whose otoscopic sensitivity and specificity (Ø85%) have been established at surgery (Bluestone & Cantekin, 1979). Otoscopic findings were classified according to position, appearance, color, and any other remarkable characteristics. When fluid was thought to be present by otoscopy, a judgment was made regarding quantity and type. An otoscopic “failure” was judged to be an ear that required medical attention because of middle ear effusion, or because of abnormalities in color or appearance. The otoscopic examination was conducted immediately before, or just after the acoustic immittance measures. The examiner was unaware of the immittance findings.

Tympanometric Classification The acoustic immittance results were analyzed according to the screening and classification procedures described in Table 2. The “traditional procedure”[‡] is essentially the original ASHA procedure, but without immediate medical referral. That is, all ears with abnormal immittance results were rescreened before medical referral. Results obtained using this procedure were compared to those acquired using the tympanometric procedures contained within the revised ASHA Guidelines for Screening for Hearing Impairment and Middle Ear Disorders (ASHA, 1990).

Results

Table 3 compares the results obtained by applying the traditional and the revised ASHA immittance procedures to the 395 ears for which valid measurements could be obtained (13 ears were eliminated because of pressure equalization tubes or impacted cerumen). The traditional

Table 2. Referral criteria for the traditional and revised ASHA immittance screening procedures. According to the revised guidelines (ASHA, 1990), immittance findings must be abnormal on two successive occasions separated by a 4- to 6-week interval. The Guidelines also recommend that immittance be performed in conjunction with pure tone screening, visual inspection, and case history.

Referral criteria for “traditional” procedure	
Tympanometric peak pressure	< -200 daPa
Acoustic reflex	Absent
or	
Flat (type B) tympanogram	
Referral criteria for revised ASHA immittance measures	
Static acoustic admittance	< 0.2 mmho
Equivalent ear canal volume	> 1.0 cmΔ
Tympanometric width	> 150 daPa

screening procedure classified 122 ears as needing medical referral (31% of the total sample). Results for the same ears classified according to the revised ASHA immittance procedure resulted in a much larger number of ears being passed on the first screen (82%); however, for those requiring rescreening, the proportion of ears passed and referred was similar. The 43 ears needing medical attention according to the revised ASHA tympanometric procedure comprised 11% of the total sample.

A summary of results obtained using the two procedures is shown in Tables 4 and 5, based on the otoscopic findings at the second screening. It can be seen that both procedures were successful in identifying most of the ears needing medical referral based on otoscopic findings. As shown in Table 4, there were no false negatives using the traditional procedure. The two false negatives obtained using ASHA’s middle ear screening procedure (Table 5) were characterized by markedly negative pressure, a measurement not included in that criteria. One of those ears was also characterized by significant abnormality of appearance (color).

Both immittance procedures were less accurate in the correct classification of nondiseased ears. As shown in Table 4, the traditional procedure correctly classified only 40% of the ears judged to be normal otoscopically (49 out of 122). Examination of data for the individual ears comprising this group revealed that nearly three-fourths failed because of absent acoustic reflexes, even though tympanometric peak pressure was less negative than -200 daPa. Most of the remainder failed because of tympanometric peak pressure more negative than -200 daPa (nearly all of these subjects had absent acoustic reflexes as well). Three

[†]The Earscan instrument now calculates tympanometric width automatically by determining the pressure interval associated with a 50% reduction in admittance on either side of the peak.

[‡]The term “traditional” is used here because the procedure is based on tympanometric peak pressure and acoustic reflexes, measures commonly used in screening for middle ear dysfunction. Although these measures have been widely used, procedures have varied considerably with respect to instrumentation, screening methods, and pass-fail criteria.

Table 3. Results of acoustic immittance screening applied to the traditional screening procedure and to the immittance measures contained within the revised ASHA protocol.

Screen 1 (<i>n</i> = 395 ears)		Screen 2 (<i>n</i> = 172 ears)	
Pass	Retest	Pass	Refer
Traditional screening procedure			
223 (56%)	172 (44%)	50 (29%)	122 (71%)
Percent of total sample referred: 31%			
Revised ASHA immittance procedure			
<i>(n</i> = 395 ears)		<i>(n</i> = 70 ears)	
324 (82%)	70 (18%)	27 (39%)	43 (61 %)
Percent of total sample referred: 11%			

ears categorized as false positives had flat tympanograms (i.e., static admittance <0.2 mmho).

The revised ASHA tympanometric procedure (Table 5) resulted in a much lower number of false positives, correctly classifying nearly three-fourths of the nondiseased ears. Examination of the 10 ears classified as false positive revealed that all failed because of abnormal tympanometric width and/or static admittance.

Comparison of the data shown in Tables 4 and 5 is complicated by the fact that different ears comprise each follow-up group. In an effort to accomplish a more direct comparison of the two immittance procedures at a single point in time, and to permit calculation of sensitivity, specificity, and predictive values, all 374 ears available for screening and otoscopic examination were classified according to the two procedures. As shown in Tables 6 and 7, comparison of sensitivity and specificity for the two procedures revealed that the traditional procedure, although highly sensitive (95%), achieved low specificity (65%). In contrast, the revised ASHA tympanometric procedure (Table 7) achieved high specificity (95%), but lower sensitivity (84%). Also of interest in Tables 6 and 7 are the predictive values calculated for the two screening procedures. For the traditional procedure (Table 6), it can be seen that a negative finding (i.e., normal tympanometric peak pressure and acoustic reflexes) was highly predictive of normal middle ear function as judged otoscopically (negative predictive value = 99%). In contrast, a positive finding predicted only about one-fourth of

Table 4. Screening results obtained when the traditional procedure was applied to the subgroup failing the initial screen (*n* = 158 ears). Only 158 of the 172 ears identified for referral in Table 3 are reported here because 14 ears could not be fully visualized otoscopically, even though valid acoustic immittance measures were obtained.

		Otoscopy	
		Fail	Pass
Immittance	Refer	36	73
	Pass	0	49

Table 5. Screening results obtained when ASHA's revised immittance procedures were applied to the subgroup failing the initial screen according to that procedure (*n* = 65 ears). Only 65 of the 70 ears identified for referral in Table 3 are reported here because 5 ears could not be fully visualized otoscopically, even though valid acoustic immittance measures were obtained.

		Otoscopy	
		Fail	Pass
Immittance	Refer	29	10
	Pass	2	24

the ears judged by otoscopy to need medical attention (positive predictive value = 27%). For the ASHA immittance measures (Table 7), the predictive value of a negative test was also very high (98%). The predictive value of a positive test (69%), although less than optimal, was considerably higher than that observed for the traditional procedure.

Examination of individual ear data for Table 6 revealed that for the two ears with normal immittance but abnormal otoscopic results, one was referred because of abnormal color/appearance, the other because of retraction and abnormal appearance. For the revised ASHA tympanometric procedures (Table 7), examination of the seven ears with normal immittance but abnormal otoscopic findings, revealed that all were characterized by negative tympanometric peak pressure, a measurement not included in that protocol. Otoscopic findings for those ears revealed abnormal color/appearance for five of the seven, and severe retraction for the remainder.

Discussion

This study was designed to examine the practical application of two immittance screening procedures, based on otoscopic examination at the time of rescreening. As such, it attempted to stimulate the practical application of the two immittance procedures, but without the inevitable delays that normally occur between referral and medical examination. Also atypical was the benefit of pneumatic otoscopy performed by a validated pediatric otolaryngologist. Most children identified in a screening program are referred to a pediatrician or family practice physician, many of whom do not use pneumatic otoscopy.

Although considerable effort was undertaken to optimize the validation criteria used in this study, several important issues must be considered. First, as Bluestone and Klein (1990) have noted, actual verification of middle ear effusion, judged otoscopically, can only be achieved by performing a myringotomy immediately after examination. Because such a validation procedure is unfeasible in a study of this nature, there is undoubtedly some degree of error in using otoscopy as a "gold standard,"

Table 6. Screening results and calculation of sensitivity, specificity, and predictive values for the traditional procedure, based on data from 374 ears evaluated by immittance screening and otoscopy.

		Otoscopy	
		Fail	Pass
Immittance	Refer	42	115
	Pass	2	215
Sensitivity	=	95%	
False negatives	=	5%	
Specificity	=	65%	
False positives	=	35%	
Positive predictive value	=	27%	
Negative predictive value	=	99%	

Table 7. Screening results and calculation of sensitivity, specificity, and predictive values for the revised ASHA immittance procedures, based on data from 374 ears evaluated by immittance screening and otoscopy.

		Otoscopy	
		Fail	Pass
Immittance	Refer	37	17
	Pass	7	313
Sensitivity	=	84%	
False negatives	=	16%	
Specificity	=	95%	
False positives	=	5%	
Positive predictive value	=	69%	
Negative predictive value	=	98%	

even though otoscopic judgments were all made by the same validated otoscopist. It is also important to note that our findings are reported “by ear” rather than “by child.” This distinction is important because, as Rockette and Casselbrant (1988) have shown, different levels of sensitivity and specificity may result depending on which methodological approach is taken. It is also important to emphasize that judgments regarding the acceptability of a given level of sensitivity or specificity can be made only in the context of disease prevalence. Although sensitivity and specificity are independent of prevalence, positive and negative predictive values (the frequency with which test results represent correct identification of individuals as affected or not affected) are highly influenced by prevalence. Thus, estimates of predictive values should be made only if there is knowledge of disease prevalence (Thorner, 1981). In the present study, 44 ears were classified as abnormal out of 395 examined, indicating a prevalence of approximately 11%. Our estimates of predictive value will undoubtedly differ from those obtained in a medical setting, where the prevalence of ear disease is much higher. This was shown in a recent study by Karzon (1991), who applied ASHA’s revised immittance measures to a group of children seen in an otolaryngology setting. Fifty-five ears from a subset of 3- to 5-yr-olds yielded a negative predictive value of 81% for static acoustic admittance and 61% for tympanometric width (positive predictive value was not reported). Sensitivity and specificity were also lower than that observed in the present study for both static admittance and tympanometric width; however, the combined hit and false alarm rates for these measures was not computed.

Attempts to use acoustic immittance for identification of middle ear dysfunction have, in general, resulted in moderate sensitivity, but low specificity. That is, most screening protocols have been reasonably accurate in identifying ears with middle ear dysfunction, but less so in correctly classifying subjects not found to require medical intervention (see Bluestone & Klein, 1991). In gener-

al, our findings using the more traditional approach were similar to those of previous investigators. The over-referral problems associated with absent acoustic reflexes and/or negative tympanometric peak pressure have been demonstrated previously (e.g., Paradise & Smith, 1978; Roush & Tait, 1985; Wachtendorf et al, 1984). The acoustic reflex, in particular, seems to contribute little to sensitivity while substantially lowering specificity.

When the two procedures are compared, the traditional immittance screening procedure, which included acoustic reflexes and measures of tympanometric peak pressure, was more successful in identifying ears needing medical attention than was the immittance procedure contained within ASHA’s revised Guidelines, which is based on measures of static admittance, physical volume, and tympanometric width. Specifically, the revised ASHA tympanometric procedure classified as normal seven ears judged by the otolaryngologist as needing medical attention. In contrast, only two false negatives occurred when the traditional procedure was applied.

It is important to emphasize that the present study examined only the immittance component contained within the revised ASHA guidelines. Margolis and Heller (1987) suggest that specificity may be increased without lowering sensitivity by providing tympanometric rescreening and by including other components, such as otological history, visual inspection, and audiometric screening, in conjunction with acoustic immittance measures. This philosophy also guided the development of the revised ASHA procedures, and specific guidelines are recommended for each of these components (ASHA, 1990). In the present study, case history information was not included, and pure tone screening, although conducted previously for these children, was not done in conjunction with middle ear screening as recommended in the revised

.....
 §In this study, the prevalence calculated “by child” (24 referrals out of 204 subjects, or 12%), was similar to the prevalence calculated “by ear” (44 ears out of 395 examined, or 11%).

ASHA guidelines. Hence, the specificity achieved by applying ASHA's revised immittance measures, although significantly higher than that obtained with the more traditional approach, might have been even higher had the ASHA procedure been applied in its entirety (i.e., in conjunction with history, visual inspection, and pure tone audiometry). Likewise, the inclusion of case history information and pure tone screening would most likely improve the overall performance of the protocol. The effects of including visual inspection are less predictable. Because five of the seven ears missed by the ASHA immittance screening protocol had marked evidence of abnormal color and appearance as well as significant retraction, a skilled nonmedical otoscopist applying the revised ASHA protocol in its entirety might have identified those individuals as needing medical referral, even though they were not identified on the basis of tympanometric findings alone. On the other hand, specificity might have been lower if the inclusion of otoscopic inspection had resulted in an excessive number of false positive medical referrals. The ASHA committee debated the issue of visual inspection at length (R.H. Margolis, personal communication), but decided that the benefits of prompt medical attention for those who needed it justified the risk of additional false positive medical referrals. The visual inspection component will need careful evaluation, however, and programs electing to include it will need to evaluate the efficacy based on their screening personnel and the nature of their target populations (Roush, 1990). This seems particularly important in view of the relatively small proportion of subjects likely to need immittance follow-up under the revised ASHA protocol. It would be regrettable if the improvements in specificity brought about by the revised tympanometric criteria were negated by excessive over-referrals based on otoscopic inspection by nonmedical personnel.

Until the new ASHA guidelines are evaluated in their entirety, the overall validity and predictive value of that protocol will be unknown. In the meantime, audiologists responsible for middle ear screening programs, regardless of the protocol they select, should evaluate their procedures carefully to ensure that they are achieving an acceptable balance between sensitivity and specificity. It is well known that failure to achieve adequate sensitivity results in absence or delay of appropriate medical management, whereas low specificity results in wasted financial resources, strained interprofessional relations, and unnecessary concern on the part of parents and caretakers. Unfortunately, few programs engage in systematic monitoring of screening outcomes. Bluestone et al (1986), at the conclusion of a conference on screening for middle ear disease, noted that "existing screening programs appear to be functioning as massive case-finding mechanisms with-

out informed guidelines to govern their activities" (p. 68). It is imperative that audiologists and health care providers work cooperatively to ensure accurate, cost-effective identification procedures and appropriate medical referral criteria.

Conclusions

The implications of this study may be summarized as follows:

1. Those electing to apply ASHA's revised immittance measures to a population with characteristics similar to the one studied here should achieve a moderate level of sensitivity, but not as high as that achieved using a more traditional procedure based on measures of tympanometric peak pressure and acoustic reflex. Specificity, on the other hand, should be much higher using ASHA's revised immittance procedures. With regard to predictive values, assuming application of the procedures to an unselected group having a similar prevalence of middle ear dysfunction, negative findings would appear to have good predictive value for both procedures. That is, normal tympanometric results should be highly predictive of normal middle ear function. In contrast, the predictive value of a positive (abnormal) outcome would appear to be much lower for both procedures. The positive predictive value for the traditional procedure was 27%, meaning that only about one-fourth of the ears failing the screen were classified otologically as needing medical intervention. The positive predictive value of the revised ASHA immittance measures, although considerably higher (69%), would still be rejected by many practitioners as too low for routine screening purposes.

2. Those electing to continue the use of a more traditional approach to middle ear screening would be well advised to eliminate the acoustic reflex from the test procedure. The acoustic reflex, as routinely applied, appears to substantially lower the specificity, while contributing little to sensitivity.

3. Applied in its entirety, the revised ASHA protocol may achieve higher or lower sensitivity, specificity, and predictive values than those observed in the present study, depending on the time interval between assessment and medical examination and the combined effects of case history, visual inspection, audiometric screening, and acoustic immittance measures. Further research is needed to determine the relative contribution of each.

References

- American National Standard Specifications for Instruments to Measure Aural Acoustic Impedance and Admittance (aural

- acoustic immittance), ANSI S3.39-1987. American National Standard Institute, New York, 1988.
- American Speech-Language-Hearing Association. Guidelines for screening for hearing impairment and middle ear disorders. *Asha* 1990;32(Suppl 2):17-24.
- American Speech-Language-Hearing Association. Guidelines for acoustic immittance screening of middle ear function. *Asha* 1979;21:550-558.
- Bluestone, C., and Cantekin, E. Design factors in the characterization and identification of otitis media and certain related conditions. *Ann Otol Rhinol Laryngol* 1979;88:13-27.
- Bluestone, C., Fria, T., Arjona, S., et al. Controversies in Screening for middle ear disease and hearing loss in children. *Pediatrics* 1986;77(1): 57-70.
- Bluestone, C., and Klein, J. Otitis media, atelectasis, and eustachian tube dysfunction. In Bluestone, C.D., Stool, S.S., and Scheetz, M.L.S., Eds. *Pediatric Oto-laryngology*, 2nd ed, Philadelphia: WB Saunders Company, 1990:320-486.
- Brooks, D.N. A comparative study of an impedance method and pure tone screening. *Scand Audiol* 1973;2:67.
- Brooks, D.N. Mass screening with acoustic impedance. In Proceedings of the Third International Symposium on Impedance Audiometry. New York: American Electromedics Co, 1977.
- Cooper, J.C., Gates, G., Owen, J., and Dickson, H. An abbreviated impedance bridge technique for school screening. *J Speech Hear Disord* 1974;40: 260.
- Harford, E.R., Bess, F.H., Bluestone, C.D., and Klein, J.O., Eds. *Impedance Screening for Middle Ear Disease in Children*. New York: Grune & Stratton, 1978.
- Holte, L., and Margolis, R. Screening tympanometry. *Sem Hear* 1987;8(4):329-337.
- Howie, V.M. Natural history of otitis media. *Ann Otol Rhinol Laryngol* 1975;19(Suppl):67-72.
- Karzon, R. Validity and reliability of tympanometric measures for pediatric patients. *J Speech Hear Res* 1991;34:386-390.
- Lous, J. Three impedance screening programs on a cohort of seven-year-old children. *Scand Audiol* 1983; (Suppl 17):60-64.
- Lucker, J.R. Application of pass-fail criteria to middle-ear screening results. *Asha* 1980;22:839-840.
- Margolis, R.H., and Heller, J.W. Screening tympanometry: criteria for medical referral. *Audiology* 1987;26: 197-208.
- Margolis, R., and Shanks, J. Tympanometry: Basic principles and clinical applications. In Rintelmann, W., Ed. *Hearing Assessment*. Austin: Pro-Ed, 1991:179-245.
- McCandless, G.A., and Thomas, G.K. Impedance audiometry as a screening procedure for middle ear disease. *Trans Am Acad Ophthalmol Otolaryngol* 1974; 78:98.
- Orchik, D.J., and Herdman, S. Impedance audiometry as a screening device with school-age children. *J Audiol Res* 1974;14:283.
- Paradise, J.L., and Smith, C.G. Impedance screening for preschool children-state of the art. In Harford, E.R., Bess, F.H., Bluestone, C.D., and Klein, J.O., Eds. *Impedance Screening for Middle Ear Disease in Children*. New York: Grune & Stratton, 1978:113-124.
- Queen, S., Moses, F., and Wood, S. The use of immittance screening by the Kansas City, Missouri Public School District. *Semin Speech Lang Hear* 1981;2:119.
- Rockette, H., and Casselbrant, M. Screening and diagnosis: methodologic issues in screening for otitis media. In Lim, D., Bluestone, C., Klein, J., and Nelson, J., Eds. *Recent Advances in Otitis Media with Effusion*. Toronto: BC Decker, 1988: 42-44.
- Roeser, R.J., and Northern, J.L. Screening for hearing loss and middle ear disorders. In Roeser, R.J., and Downs, M.P., Eds. *Auditory Disorders in School Children*, 2nd ed. New York: Thieme-Stratton, 1988:53-82.
- Roush, J. Identification of hearing loss and middle ear disease in preschool and school-age children. *Semin Hear* 1990;11:357-371.
- Roush, J., and Tait, C. Pure tone and acoustic immittance screening of preschool-age children: An examination of referral criteria. *Ear Hear* 1985; 6(5):245- 249.
- Schow, R.L., Pederson, J.K., Nerbonne, M.A., and Boe, R. Comparison of ASHA's immittance guidelines and standard medical diagnostic procedures. *Ear Hear* 1981;2(6):251-255.
- Teele, D.W., Klein, J., and Rosner, B. Epidemiology of otitis media in children. *Ann Otol Rhinol Laryngol* 1980;89(Suppl 68):5-6.
- Wachtendorf, C.A., Lopez, L.L., Cooper, J.C., Hearne, E., and Gates, G. The efficacy of school screening for otitis media. In Lim, D.J., Bluestone, C.D., Klein, J.O., and Nelson, J.D., Eds. *Recent Advances in Otitis Media*. Toronto: BC Decker, 1984:242-246.

Acknowledgments

The authors thank Robert Margolis and Joseph Hall for their comments and recommendations on an earlier draft of the manuscript. We are also grateful to reviewers Robert Nozza and Ross Roeser for their helpful suggestions on improving this report. Special thanks to the children and staff of the Headstart programs of Duplin County, North Carolina.

Address reprint requests to J. Roush, Campus Box 7190, Wing D-Medical School, University of North Carolina, Chapel Hill, NC 27599.

Received February 4, 1991

Accepted April 18, 1991

Modeling the Cost and Performance of Early Identification Protocols

Robert G. Turner

University of California, San Francisco, California

Abstract

This is the first in a series of three papers concerned with the early identification of hearing loss. In this paper, a simple model is presented that permits the calculation of the performance and cost of early identification protocols. In the second paper (Turner, in press), this model is used to compare four early identification protocols that differ in hearing screening strategies. The third paper (Turner, in press) examines the factors that influence the early identification protocol. The model described in this paper is sufficiently general to accommodate most early identification strategies including those that meet the goal of identification and habilitation by 6 months. The model measures protocol performance using hit rate, false alarm rate, and selected posterior probabilities. The model also calculates two measures of the financial cost. One measure reflects the cost of implementing the protocol; the other reflects the cost-effectiveness of the protocol. The parameters required by the model are also specified and are based on published clinical data. The model is provided to help audiologists design and select early identification protocols that are optimum for their particular clinical situation.

Key Words: Hearing loss, early identification, infant, model, cost-benefit analysis

It is generally accepted that hearing-impaired children benefit from the early detection and habilitation of hearing loss. The Joint Committee on Infant Hearing (1982) has recommended that hearing loss be identified and habilitation begun by 6 months of age. The need for such an effort is clear to most audiologists, but how does one determine the most appropriate early identification (EID) protocol?

One approach is to rely entirely on intuition and clinical experience. This, however, is only appropriate with extremely complex problems that defy any type of quantitative analysis. Unfortunately, this strategy is often used because it is the least demanding. While it has a certain appeal, such a subjective approach is often vulnerable to bias and undetected error. Decisions may be based on inappropriate assumptions that result from atypical or limited clinical experience. Also, it is difficult to evaluate and validate the decision making process because it is seldom explicitly known.

Another strategy is to quantify every variable and then perform a detailed cost-benefit analysis. Theoretically, this is the best approach, but often it is too difficult to be practical. With this strategy it is necessary to assign some quantitative measure of cost to errors and benefit to correct decisions. The problem is

that some important variables may be difficult or near impossible to quantify. For example, what are the actual financial and societal costs of not identifying a hearing-impaired infant?

There is a third strategy that is a compromise between the two described above. A simplified model can be developed to serve as an objective, defensible starting point. With this model, certain issues can be evaluated quantitatively. Factors that can not be included in the model can then be considered to yield the ultimate decision. Thus, the cost-benefit analysis combines objective data derived from a quantitative model with a subjective evaluation of important factors. While there is a subjective component to this strategy, at least the decision process begins with a more rigorous, objective foundation.

What factors would we want to quantify in a model? There are many important factors to consider when selecting an EID protocol, but the two most fundamental are performance and cost. By performance, we mean how many hearing-impaired (IH) infants will be detected. It would also be useful to know how many normal hearing (NH) infants will be incorrectly called hearing impaired. Since resources are limited, some measure of the cost of implementing an EID protocol is essential, as well as some measure of cost-effectiveness. Thus, reasonable measures of performance and cost are the minimum information we would want when evaluating and selecting EID protocols. It is dif-

difficult to see how an appropriate decision can be made without this basic information. Fortunately, performance and cost, the most basic factors, are also the easiest to quantify in a model.

Prager et al (1987) used a simple model to compare the cost-effectiveness of newborn hearing screening with the Crib-O-Gram and auditory brainstem response techniques. This paper extends their work and presents a more general and detailed model for EID protocols. The techniques for calculating the cost and performance of EID protocols are described in detail. Essential data for the implementation of these techniques is also provided.

This model is easy to implement and can be used by audiologists to develop their own EID protocols. The quantitative results of this model can be considered along with more subjective local factors to evaluate different EID strategies. Each program can design an EID protocol that is optimum to its particular need instead of relying on one universal recommendation.

Protocol Design

The first step in developing the model is to specify the basic design of the EID protocol (Fig. 1). This design is sufficiently general to accommodate many actual protocols. With certain implementations, it is consistent with the goal of identification and habilitation by 6 months. The model does not consider the identification of progressive loss.

Nursery

The first component is the hospital nursery. This can be either a well baby nursery (WBN) or an intensive care nursery (ICN). It is necessary to distinguish between the types of nurseries because prevalence of hearing loss can be very different. In addition, screening tests may perform very differently on infants from

the two nurseries. In general, infants in either nursery are referred to a screening protocol; however, this is not essential.

Screening Protocol

The primary purpose of any screening protocol is to reduce the cost of identification. The screening protocol identifies infants at risk, that is, infants with a higher probability of disease than the general population. This reduces the infants who must be followed and tested with the diagnostic procedures, reducing the cost of identification. Usually, the result of screening is either pass or fail; the screening is not diagnostic. Infants that fail are referred for diagnostic testing. Infants that pass are not followed. Experience has shown that with some screening protocols, all infants cannot be tested before discharge. A provision for this is incorporated in the model.

Follow-Up

Technical limitations prevent the diagnostic testing of newborns; therefore, infants must be followed until they are sufficiently old for diagnostic procedures. Both infants who fail the screening and infants who were not screened before discharge must be followed. The reason that this component must be explicitly shown in the model is that there is some expense in following infants until diagnostic testing. In addition, experience has demonstrated that some infants will be lost from follow-up. Both factors will have a significant impact on the cost and performance of EID protocols.

Diagnostic Protocol

The final component in the EID process is the diagnostic protocol. It is this component that actually

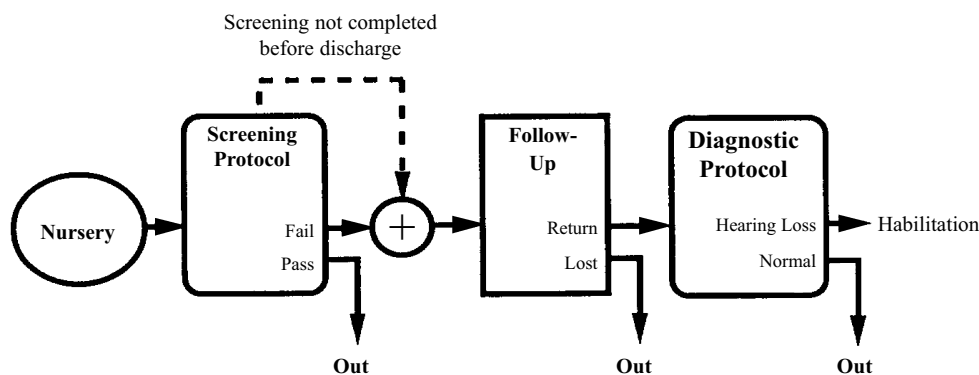

Figure 1. Basic early identification protocol design. "Out" means that an infant is no longer tested or followed by the protocol.

identifies hearing loss. Infants with hearing loss are referred for additional evaluation, habilitation, and management.

Measures of Performance and Cost

Simple, but adequate, measures of test performance are hit rate (HT) and false alarm rate (FA). These same measures can be applied to test protocols (Turner et al, 1984). Hit rate for the EID protocol (HTp) is the percentage of hearing-impaired infants in the nursery who are identified by the protocol. False alarm rate for the protocol (FAp) is the percentage of normal hearing infants in the nursery who are incorrectly called hearing impaired by the protocol.

Also of interest are the posterior probabilities. One posterior probability (PPf) is the probability of hearing loss in an infant who fails screening. PPf indicates how much confidence we can have that an infant who fails is actually hearing impaired. A second posterior probability is PPp. This is the probability of hearing loss in an infant who passes screening.

There are many different measures of financial and societal costs that could be used. For our purposes, we will restrict our calculations to two basic measures of financial cost. These are the dollar cost of the EID protocol per infant in the nursery (CPIN) and the dollar cost of the EID protocol per hearing-impaired infant identified (CPHL). These two measures reflect different aspects of protocol costs. CPIN is a measure of what it costs to implement the program, whereas CPHL is a measure of cost-effectiveness. A program could be inexpensive to implement, but could identify few IH infants. In this case, CPIN would be low but CPHL would be large. On the other hand, an expensive program could identify many IH infants. CPIN would be large, but CPHL small.

Model Parameters

To calculate performance and cost for an EID protocol, it is necessary to specify the parameters that are used in the model. For calculating performance, the parameters are disease prevalence, HT/FA of the individual tests in the protocol, and test correlation (Turner et al, 1984).

To determine CPIN and CPHL we must know the cost of each component of the EID protocol plus protocol performance. Hit rate and false alarm rate of the total protocol are not sufficient; we must also know the number of infants processed by each component. This means tracking the infants, in detail, all the way through the EID protocol.

For EID protocols, two additional factors must be considered. First, the percentage of infants who cannot be screened in the nursery are combined with the screening failures to constitute the infants to be followed. Second, it is necessary to specify a follow-up percentage. This is the percentage of infants who remain in the program until diagnostic testing.

In general, the model parameters will be derived from published clinical data. This is not without some problems. For many parameters the reported values can vary significantly. A parameter will be selected that is the average of the reported values or is within the approximate middle of the reported range. An additional problem is that some of the parameters have received little attention in the literature. In this case a best guess will be made based on available information. A summary of the selected model parameters is shown in Table 1.

Prevalence

Prevalence (Pr) is the percentage of infants in a nursery with hearing loss at the time of testing. Determining prevalence is more complex than it may seem. The first problem is defining hearing loss in terms of degree of loss, type of loss, and unilateral versus bilateral hearing loss. Historically, most prevalence data, particularly for the general population, have been for moderate to profound sensorineural loss. Newer techniques in the ICN have made possible the detection of milder losses, conductive losses, and unilateral losses. For our purposes, we will focus on the identification of moderate to profound sensorineural loss, unilateral or bilateral.

A number of studies provide estimates of prevalence for the ICN. Some good reviews of relevant studies are provided in Murry et al (1985), Jacobson and Hyde (1986), and Stein (1986). Estimates of prevalence vary from about 1 to 8% with the generally accepted range being 2 to 4 percent (Committee on Infant Hearing, 1989). If conductive loss was included, then the prevalence would be higher. Three percent will be used as the model parameter for prevalence in the ICN.

We are also interested in the prevalence in the WBN. In general, this figure has not been determined directly; we must estimate this from data for the general population. Reported prevalence has varied from less than 0.1 to more than 0.3 percent, but the most frequent reports are 0.1 to 0.2 percent (see Peckham, 1986; Riko et al, 1985 for reviews). We would expect the prevalence in the WBN to be smaller than the general population for two reasons. In many studies preva-

Table 1. Base Parameters Used with Model

	Performance		Cost	
	ICN	WBN	Min./Test	\$/Test
Pr: Prevalence (%)	3.0	0.1		
CNT: Can Not Test Before Discharge (%)	10	10		
HRR: High Risk Register			10	13
Hit rate (%)	95	60		
False alarm rate (%)	65	10		
ABR: Auditory Brainstem Response Screening		45	60	
Hit rate (%)	95	95		
False alarm rate (%)	15	10		
FU: Follow-Up Success (%)	50	50	10	13
Diagnostic Protocol			120	160
Hit rate (%)	100	100		
False alarm rate (%)	0	0		
Test Correlation	Zero	Zero		

lence is based on hearing loss in children from 5 to 8 years of age. Some of the measured hearing loss would be progressive and not present in the WBN. Also, the general population consists of infants from the WBN and the ICN where the prevalence of hearing loss is greater. We will use 0.1 percent (1 per 1000) as the model parameter for prevalence in the WBN.

Screening Test Performance

A variety of different tests have been used to screen infants for hearing loss. Today, the only tests in extensive use are the high-risk register (HRR) and auditory brain stem response (ABR) screening; therefore, we will concentrate on these two tests for the model. As new screening tests are developed, these can be incorporated into the model as long as the hit rate and the false alarm rate can be specified.

The performance of some screening tests can be quite different in the two nurseries; therefore, the nurseries must be considered separately. Remarkably, there is little information in the literature on the performance of the HRR in the ICN even though the HRR has been employed in many studies. Frequently, the HRR has been used to determine which infants receive ABR screening without any attempt to evaluate the performance of the HRR. One study (Simmons et al, 1979) found HT/FA = 96/64 percent for the HRR in the ICN.

Several studies do report failure rate (FR) for the HRR. These rates have varied significantly from 20 to more than 90 percent (Alberti, 1986; Hosford-Dunn et al, 1987; Swigonski et al, 1987; Kramer et al, 1989). FR can provide an estimate of false alarm rate. When prevalence is low, the FA will be only a few percent

smaller than FR. With a FR of 20 percent, a 3 percent prevalence would yield a FA of almost 18 percent. Thus, the FA for the HRR in the ICN will vary as the FR varies. In general for a diagnostic test, as false alarm rate decreases so does hit rate. Thus, a low FR means a low FA, which may indicate a low HT. Unfortunately, there is no information on the HT of the HRR when FR is low. We will use as a model parameter, HT/FA = 95/65 percent, consistent with the results of Simmons et al (1979).

There is information on the performance of the HRR in the WBN and the general population (Mencher, 1974; Feinmesser and Tell, 1976; Downs, 1978; Simmons et al, 1979; Feinmesser et al, 1982; Mencher and Mencher, 1982; Stein et al, 1983; Alberti, 1986; Coplan, 1987; Elssmann et al, 1987; Kramer et al, 1989). The results of the two populations are similar, although we would theoretically expect a slightly higher HT and FA for the general population because that would include ICN infants. HT varies from approximately 50 to 75 percent; FA from approximately 7 to 12 percent. We would expect some variation because different high-risk items have been employed. In general, the more restricted the HRR, the lower the HT and FA. Feinmesser and Tell (1976) found the performance of the HRR reduced from HT/FA = 72/20 percent to 60/7 percent when fewer items were used. We will use HT/FA = 60/10 percent for the model parameter for the HRR in the WBN.

There is limited information on the HT of ABR screening in the ICN. To determine hit rate, it is necessary to know how many hearingimpaired infants were missed by the screening. This means that infants who *pass* the screening must be followed; unfortunately, this

is seldom done. Three studies attempted to follow all infants that had been screened with ABR (Shannon et al, 1984; Bradford et al, 1985; Swigonski et al, 1987). In all studies, HT = 100 percent for the ABR screening, but in each case the number of infants tested was relatively small. In the largest relevant study, over 700 infants were followed (Hyde et al, 1990). HT for ABR screening varied from 98 to 100 percent depending on criterion for passing the screen. It is important to note that in this study, infants were tested under ideal conditions at 3 months of age or later, not in the ICN. In addition, this study did not consider low frequency loss that can be missed by ABR testing with a click stimulus. These studies indicate a high HT for ABR screening; however, we would not expect HT = 100 percent. A small number of hearing-impaired infants could be missed because they have low frequency loss or because a high click level (e.g., 40 dB nHL) was used for the criterion (Riko et al, 1985; Durieux-Smith et al, 1987; Kramer et al, 1989). For the model parameter, we will use HT = 95 percent for the ABR in the ICN.

There are extensive data on the failure rate of the ABR in the ICN. A number of studies have been summarized by Murry et al (1985), Jacobson and Hyde (1986), and Stein (1986). In general, FR varies from 10 to 25 percent in these reviews with an average FR (as calculated from Murry et al and Jacobson and Hyde) of about 17 percent. As discussed previously, the FA will be several percent below the FR. A FA of 15 percent will be used as the model parameter so as to reflect general experience, not optimum performance. Recent improvements in technique may consistently improve the FR for ABR. Gorga et al (1988) tested ICN infants under ideal conditions, including insert earphones, and found that only 5 percent of the ears failed the screening. This corresponds to a failure rate of 5 to 10 percent depending on the distribution of impaired ears among the infants.

There is little information on the performance of ABR screening in the WBN. This strategy has seldom been used because of the large number of infants to be tested and the low prevalence of hearing loss. There is no obvious reason to expect the HT in the WBN to be much different than in the ICN. As for the ICN, we will use HT = 95 percent as the model parameter. We would expect the FA in the WBN to be lower than the ICN. There would be fewer infants in the WBN with developmental delays or transient conductive loss. A lower limit on false alarm rate is indicated by the work of Hyde et al (1987). They tested more than 200 normal infants who were not at-risk for a hearing loss. The infants were screened at approximately 4 months with ABR under ideal conditions, except that insert phones were not used. They found a FR of 7 percent

for a 30 dB nHL click stimulus. Assuming no hearing-impaired infants in this population, the FA would be identical to the FR. We would expect the FR to be slightly higher in newborns, as opposed to 4 months; therefore, FA = 10 percent will be used as the model parameter.

Cannot Test

Certain screening tests such as ABR require physical access to the newborn in the nursery. In the ICN, testing is most reliable when the infant is less ill, that is, right before discharge. This significantly reduces the time available for testing. In the WBN, infants may be hospitalized for only 2 or 3 days, again reducing the opportunity for testing. A certain percentage of infants (CNT) will be discharged before testing can be accomplished. This issue is seldom discussed in published studies, but conceivably could impact on the cost and performance of EID protocols. Durieux-Smith et al (1987) reported that 21 percent of the infants could not be screened with ABR before discharge. On the other hand, Kramer et al (1989) were able to test 95 percent of infants with ABR before discharge. For screening protocols that use ABR, we will use CNT = 10 percent as the model parameter; otherwise, CNT = 0 percent.

Follow-Up Percentage

Another important parameter that has received little attention in the literature is followup percentage (FU). This is the percentage of infants that are successfully followed until diagnostic testing. There has been no specific study of follow-up rates or the factors that influence follow-up success. Several studies do give some indication of follow-up, but usually without much detail as to the procedure for following infants (Mencher, 1974; Simmons et al, 1979; Stein et al, 1983; Durieux-Smith et al, 1987; Elssmann et al, 1987; Swigonski et al, 1987; van Zanten et al, 1988; Kramer et al, 1989). In these studies, follow-up percentages varied from 40 to 90 percent. Jacobson and Hyde (1986) summarize about a dozen studies (Table 5-2, pg. 93) and indicate the number of infants tested at follow-up. Follow-up percentages ranged from 32 to 100 percent with an average of 50 percent.

The author was involved with an EID program that included initial diagnostic testing at several months. Long-term follow-up success to that appointment was about 50 percent with a modest effort to recall infants for testing (Jacobson et al, 1990). Based on this very limited information, FU = 50 percent will be used for the model parameter.

Diagnostic Protocol

We would expect the performance of any reasonable diagnostic protocol to be quite good, although not necessarily perfect. Hyde et al, (1990) found ABR screening at several months to have excellent performance (HT/FA = 98/4 percent). More comprehensive ABR testing combined with other procedures should yield a performance as good as, or better than, ABR screening. Behavioral testing at an appropriate age should also have excellent performance. For this model, it is reasonable to assume that the diagnostic testing is definitive, that is, HT/FA = 100/0 percent. This simplifies calculations and should not introduce much error. In reality, we would expect an occasional miss or false alarm. The number, however, would be so small as to have little effect on the cost and performance of the EID protocol. In addition, the diagnostic protocol would usually be the same when comparing different screening protocols. Any errors would impact on all protocols and have little impact on their relative cost or performance.

Costs

To determine protocol costs, it is necessary to specify the cost of the individual components in the protocol. This would include the screening and diagnostic tests and follow-up. Specifying these costs is difficult; actual expense could vary significantly with institution. Also, there is little information in the literature as to the expense of testing and follow-up.

Costs were determined based on the time required to provide the service. It was assumed that there was a general expense of \$80 per hour for any activity. What we assume for this rate is not particularly critical if our primary interest is in comparing the relative costs of different protocols. The time required per infant for each activity is given in Table 1. This was multiplied by \$80/hour to determine the cost per infant tested or followed.

There is a tendency to ignore the cost of a HRR. Some minimum time is required to review charts and identify those infants to be followed or screened. Ten minutes per infant was assumed for a cost of \$13. A time of 45 minutes per infant was assumed for ABR screening. This would include testing time, set-up time, travel time to the nursery, reports, and record keeping. The cost for ABR screening is \$60 per infant.

A follow-up of 50 percent was specified for the model. This was based, in part, on the author's own experience with an EID program. In that program, all record keeping was performed by computer. Infants

were automatically identified for follow-up with minimum labor expense. The effort to retrieve infants for testing was modest. On this basis, 10 minutes per infant was assumed for follow-up to the first visit for a cost of \$13.

The final component is diagnostic testing. The actual composition of this protocol could vary significantly, thus producing a significant variation in cost. To illustrate the techniques, we will assume a particular diagnostic strategy that consists of ABR threshold testing plus some limited behavioral and immittance audiometry. Infants that demonstrate hearing loss would return for additional audiologic testing and evaluation by other professionals. This is a streamlined strategy; 2 hours are specified for this protocol resulting in a cost of \$160 per infant.

Test Correlation

Test correlation is the tendency of two tests to identify the same patients the same way. Test correlation can have a significant impact on protocol performance. Limited clinical data suggest that audiologic tests that distinguish cochlear from retrocochlear site of lesion have a mid-positive correlation (Turner et al, 1984). There is essentially no information on correlation for the tests commonly used in an EID protocol.

For this model, we will assume a test correlation of zero. This means that the tests are independent; the results on one test do not influence the other. To illustrate, consider two tests, A and B. Test A evaluates a group of infants. Test B evaluates the infants that fail Test A. If the tests have zero correlation, then the hit rate and false alarm rate of Test B would be the same on the original population of infants as on the subpopulation that failed Test A. If correlation was not zero, this would not be true.

An assumption of zero correlation simplifies the calculation for the model. This assumption is reasonable for several reasons. Test correlation is only an issue when two or more tests are combined. If one of the tests has perfect performance (HT/FA = 100/0 percent), then test correlation does not matter. We have assumed perfect performance for the diagnostic protocol; thus, correlation between the screening protocol and the diagnostic protocol is not an issue. The only time we must worry about test correlation is when the screening protocol consists of two or more tests. We have limited our interest to just two screening tests, HRR and ABR. The mechanics of these two tests are so different that there may, in fact, be little correlation between these tests. When these two tests are combined

into a screening protocol, we will assume zero correlation.

Example

There are two ways to determine protocol performance and cost. It is possible to derive explicit equations for the EID protocol in Figure 1 that would permit the direct calculation of HTp, FAp, CPIN, and CPHL using model parameters. These equations, however, would be fairly complex. In addition, there would be no information as to the characteristics of a protocol other than the calculated measures of cost and performance.

A second technique is to track infants through the EID protocol by calculating performance and cost at each component. Ultimately, HTp, FAp, CPIN, and CPHL are calculated, but there is much additional information provided as to the contribution of each component to the overall cost and performance of the protocol. This strategy will be illustrated by an EID protocol that uses ABR as the screening component. The model parameters from Table 1 are used.

Protocol Performance

Protocol performance is calculated first (Fig. 2). We assume that there are 100 infants in the nursery. The actual number of infants is not important because hit rate and false alarm rate are relative measures independent of the number of infants tested. The infants in the nursery are divided into 3 IH infants and 97 NH, consistent with a prevalence of 3 percent.

Ten percent of the infants are discharged before screening (CNT). This 10 percent is applied to both subpopulations of infants. Thus 0.3 IH infants and 9.7 NH infants are not screened. For convenience, there is some rounding of the number of infants. Thus, the 9.7 NH infants are rounded to 10.

A total of 89.7 infants (2.7IH/87NH) will be screened. The HT/FA of the screening protocol is 95/15 percent. The next step is to calculate the number of hits, misses, false alarms, and correct rejections that result from the screening protocol. The number of hits (2.6) is the number of IH infants who are screened (2.7) times the hit rate of the screening protocol (95% = 0.95). The remaining 0.1 IH infants (2.7 - 2.6 = 0.1) constitute the misses. Likewise, the false alarms (13) equal the number of NH infants screened (87) times the false alarm rate (15%). The remaining 74 NH infants (87 - 13 = 74) are the correct rejections.

The posterior probabilities can also be calculated. PPf, the probability of hearing loss in an infant who fails

the screening, is simply the prevalence of hearing loss in the population of infants who fail. This is the number of IH infants (2.6) divided by the total number of infants who fail (2.6 + 13). For this protocol, PPf is 17 percent. PPP, the probability of hearing loss in an infant who passes the screen, is the prevalence of hearing loss in the infants who pass. This is less than 1 percent.

The misses and correct rejections (0.1/74) are the infants who pass the screening protocol and are no longer followed. The hits and false alarms (2.6/13) are the infants who have failed the screening protocol and are referred for follow-up. These are combined with the infants who were not screened before discharge to generate a total of 2.9 IH infants and 23 NH infants who are to be followed.

The follow-up percentage (FU) is assumed to be 50 percent for both IH and NH infants. The number that return for diagnostic testing is the number followed times FU. In this example, half the infants are followed and half are lost from follow-up. The actual number followed are rounded to 1.4 IH and 11 NH infants.

The diagnostic protocol is assumed to have perfect performance (i.e., HT = 100% and FA = 0%). Again, the number of hits (1.4) is the number of IH infants tested (1.4) times the diagnostic protocol hit rate (100% = 1.0). This means that all IH infants will be correctly identified as hearing impaired; there are no misses. The number of false alarms (0) will be the number of NH infants tested (11) times the false alarm rate (0%). All NH infants will be correctly identified as normal hearing; thus, there are 11 correct rejections and no false alarms.

The EID protocol hit rate (HTp) is the number of diagnostic protocol hits (1.4) divided by the number of IH infants in the nursery (3). Thus, we have

$$\text{HTp} = \frac{1.4}{3} = 46\%.$$

The protocol false alarm rate (FAp) is the number of diagnostic protocol false alarms (0) divided by the number of NH infants in the nursery (97). Thus,

$$\text{FAp} = \frac{0}{80} = 0\%$$

As we would expect, the protocol false alarm rate will always be zero if the diagnostic protocol has FA = 0%.

Protocol Costs

Protocol costs for the example protocol (Fig. 3) are calculated next. To determine CPIN and CPHL, it

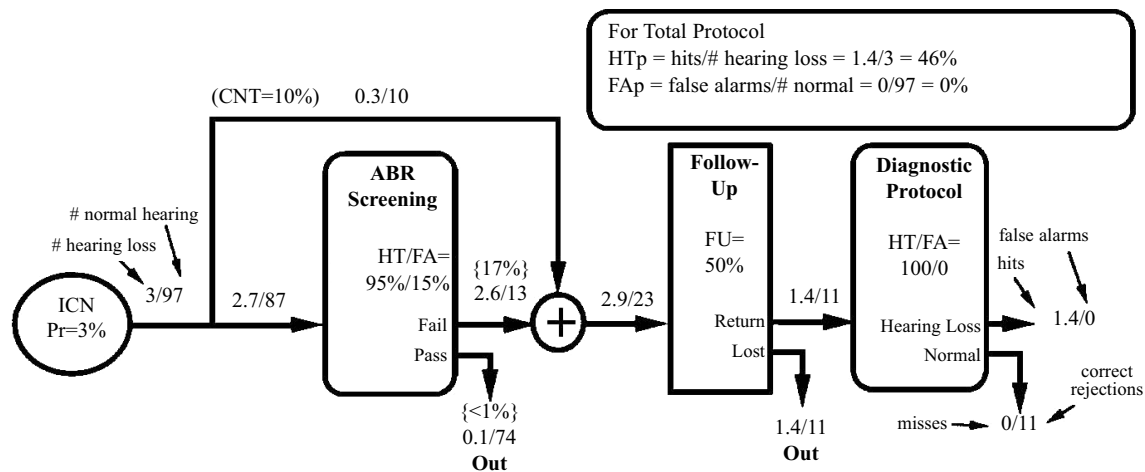

Figure 2. Calculations of performance for example protocol when used in the intensive care nursery (ICN). In this example, the screening protocol consists of auditory brainstem response (ABR) screening. The 17 percent in brackets is the posterior probability that an infant who fails screening actually has a hearing loss. The <1 percent is the probability that an infant who passes screening has a hearing loss. Pr = prevalence of hearing loss; HT/FA = hit rate/false alarm rate; CNT = percentage not screened before discharge; FU = follow-up success; and HTP/FAP = hit rate/false alarm rate of early identification protocol.

is first necessary to calculate the total cost of the EID protocol (see Fig.3). The parameters are the same in this example as in Figure 2. The costs of the individual components are from Table 1. Again it is assumed that 100 infants will be tested. While total cost is a function of the number of infants tested, CPIN and CPHL are relative measures independent of the number of infants. When calculating cost, it does not matter if an infant is hearing impaired or has normal hearing. Unlike when calculating performance, it is not necessary to separate the infants into an IH subpopulation and a NH subpopulation. What is important is the total number of infants processed by each component of the protocol.

There are 89.7 infants to be screened by ABR at a cost of \$60 per infant. The total cost of the screening protocol (\$5382) would be the number of infants screened (89.7) times the cost per infant (\$60). The next component is follow-up. From the performance calculations (see Fig. 2), we see that a total of 25.9 infants are to be followed. The total cost of follow-up (\$337) is the number of infants followed (25.9) times the cost per infant (\$13). A total of 12.4 infants receive diagnostic testing. The total cost of diagnostic protocol (\$1984) is the number of infants tested (12.4) times the cost of diagnostic testing (\$160).

The total cost of the EID protocol is the sum of the cost of the individual components (\$5382 + \$337 + \$1984 = \$7703). The cost per infant (CPIN) equals the total cost of the EID protocol divided by the number of infants in the nursery (\$7703/100 = \$77). The cost per impaired infant identified (CPHL) equals the total pro-

col cost divided by the number of total protocol hits. From Figure 2, there are 1.4 protocol hits; thus,

$$\text{CPHL} = \frac{\$7703}{1.4} = \$5500.$$

Discussion

Modeling EID protocols serves several important purposes. It forces us to consider all components of the EID process and the factors that influence performance and cost. It is easy to focus on one aspect, such as screening, and lose sight of the ultimate objective, which is the identification of hearing-impaired infants. There is a tendency to choose an EID protocol on the basis of the screening component, not the total protocol. The model forces us to consider total protocol cost and performance, the most basic factors, when developing an EID strategy.

With this model, we have identified issues, such as follow-up, that have been largely over-looked, but that can have a significant impact on the EID process. In addition, this work has revealed deficits in the published literature as to information essential for the evaluation of EID protocols. For example, the HRR is used extensively in the ICN, but there is little information as to its performance.

With this model, it is possible to explore the relationship between model parameters and the ultimate cost and performance of the EID process. This can be accomplished by using the model to calculate cost and performance while a model parameter is varied within

a range that reflects actual clinical experience. For example, how does prevalence of hearing loss influence the design of a protocol? Would we want a different protocol if follow-up percentage was low instead of high? Consideration of such issues helps provide a better theoretical foundation for the development and selection of EID protocols.

An important feature of this model is the ability to compare different potential EID protocols on the basis of cost and performance. This would be particularly useful for hospitals that are going to establish an EID program and have no previous clinical experience. While actual experience may ultimately be somewhat different than indicated by the model, the model would still provide essential information as to the advantages and disadvantages of different protocols. This type of model is the only way to generate reasonable estimates of cost and performance when clinical data are not available.

Many hospitals have implemented EID programs. This model could be used to better estimate the expense and cost-effectiveness of an existing program. The accuracy of these estimates would be a function of the parameters that were specified for the model. Care was taken when reviewing the clinical literature to derive reasonable estimates of these parameters; however, some model parameters could vary significantly with institution. The accuracy of the model could be improved by using parameter values that better reflect local experience.

Tests other than the HRR and ABR may be used for screening. Otoacoustic emissions is one technique that is currently being evaluated for this purpose (Stevens et al, 1990). Any procedure can be incorporated into the model provided there are reasonable estimates available for hit rate, false alarm rate, and cost of testing.

This model provides a more objective basis for the selection of an EID protocol. It generates a quality and quantity of information that is not available elsewhere. This information can be combined with other important factors, not considered in the model, to produce a reasonable, defensible cost-benefit analysis.

Summary

Ideally, the selection of an early identification (EID) protocol should be based on a detailed, quantitative cost-benefit analysis. Practical considerations make this impossible. A good alternative to a totally subjective decision process is one based on a combination of quantitative data and qualitative factors. The quantitative data can be supplied by a simple model for the EID protocol. With this model, useful measures of protocol performance and cost can be easily calculated. The model is sufficiently general to accommodate most early identification strategies including those that meet the goal of identification and habilitation by 6 months. The parameters required by the model are also specified and are based on published clinical data.

This model is provided to help audiologists select an EID protocol that is optimal for their particular situation. If local experience indicates parameter values different than those specified in this paper, then the more appropriate values should be used. Hopefully, the concepts described in this paper will result in a more rigorous, defensible strategy for the selection of EID protocols.

Acknowledgment

Presented in part at the meeting of the American Academy of Audiology, New Orleans, LA, April, 1990.

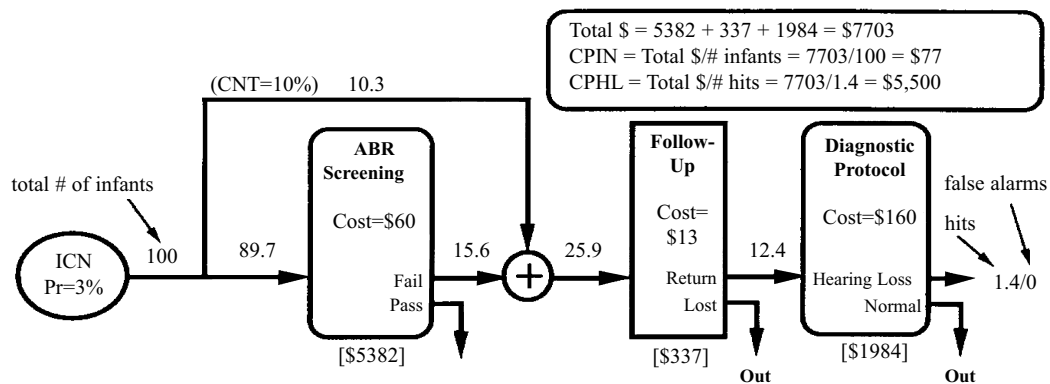

Figure 3. Calculations of costs for example protocol when used in the intensive care nursery (ICN). Dollar amount in brackets is the total cost for each component in the early identification protocol. Cost = expense of testing or follow-up for each infant; CPIN = cost per infant in nursery; CPHL = cost per hearing-impaired infant identified.

References

- Alberti, P.W. (1986). An evaluation of hearing screening in high risk infants using BERA. *Audiol Pract* 2:3-4.
- Bradford, J.B., Baudin, J., Conway, M.J., Hazell, J.W.P., Stewart, A.L., and Reynolds, E.O.R. (1985). Identification of sensory neural hearing loss in very preterm infants by brainstem auditory evoked potentials. *Arch Dis Child* 60:105-109.
- Committee on Infant Hearing. (1989). Audiologic screening of newborn infants who are at risk for hearing impairment. *Asha* March: 89-92.
- Coplan, J. (1987). Deafness: Ever heard of it? Delayed recognition of permanent hearing-loss. *Pediatrics* 79:206-213.
- Downs, M.P. (1978). Auditory screening. *Otolaryngol Clin North Am* 11:611-629.
- Durieux-Smith, A., Picton, T., Edwards, C., MacMurray, B., and Goodman, J. (1987). Brainstem electric response audiometry in infants of a neonatal intensive care unit. *Audiology* 26:284-297.
- Elssmann, S., Matkin, N., and Sabo, M. (1987). Early identification of congenital sensorineural hearing impairment. *Hear J* 40:13-17.
- Feinmesser, M.D., and Tell, L.T. (1976). Neonatal screening for the detection of deafness. *Arch Otolaryngol* 102:297-299.
- Feinmesser, M., Tell, L., and Levi, H. (1982). Follow-up of 40000 infants screened for hearing defect. *Audiology* 21:197-203.
- Gorga, M., Kaminski, J., and Beauchaine, K. (1988). Auditory brain stem responses from graduates of an intensive care nursery using an insert earphone. *Ear Hear* 9:144-147.
- Hosford-Dunn, H., Johnson, S., Simmons, B., Malachowski, N., Low, K. (1987). Infant hearing screening: Program implementation and validation. *Ear Hear* 8:12-20.
- Hyde, M.L., Matsumoto, N., and Alberti, P.W. (1987). The normative basis for click and frequency-specific BERA in high-risk infants. *Acta Otolaryngol (Stockh)* 103:602-611.
- Hyde, M.L., Riko, K., and Malizia, K. (1990). Audiometric accuracy of the click ABR in infants at risk for hearing loss. *J Am Acad Audiol* 1:59-66.
- Jacobson, G.P., Burtka, M.J., Wharton, J.A., Newman, C.W., Shepard, N., and Turner, R.G. (1990). Infant hearing screening 1984 to 1989: The Henry Ford Hospital experience. *Henry Ford Hosp Med J* 38(1):39-43.
- Jacobson, J.T., and Hyde, M.L. (1986). The auditory brainstem response in neonatal hearing screening. In: Swigart, E.T., ed. *Neonatal Hearing Screening*. San Diego: College-Hill Press, 67-95.
- Joint Committee on Infant Hearing. (1982). Position statement. *Asha* 24:1017-1018.
- Kramer, S., Vertes, D., and Condon, M. (1989). Auditory brainstem responses and clinical follow-up of high-risk infants. *Pediatrics* 83:385-392.
- Mencher, G.T. (1974). Infant hearing screening: State of the art. *Maico Audiological Library Series* 12(7).
- Mencher, G.T., and Mencher, L.S. (1982). Report of a three year early identification of hearing loss program. *Paper presented at the Biannual Meeting of the International Society of Audiology, Helsinki*.
- Murry, A.D., Javel, E., and Watson, C.S. (1985). Prognostic validity of auditory brainstem evoked response screening in newborn infants. *Am J Otolaryngol* 6:120-131.
- Peckham, C.S. (1986). Hearing impairment in childhood. *Br Med Bull* 42:145-149.
- Prager, D.A., Stone, S.A., and Rose, D.N. (1987). Hearing loss screening in the Neonatal Intensive Care Unit: Auditory brain stem response versus Crib-O-Gram; A cost-effectiveness analysis. *Ear Hear* 8:213-216.
- Riko, K., Hyde, M.L., Alberti, P.W. (1985). Hearing loss in infancy: Incidence, detection, and assessment. *Laryngoscope* 95:137-144.
- Shannon, D.A., Felix, J.K., Krumholz, A., Goldstein, P.J., and Harris, K.C. (1984). Hearing screening of high-risk newborns with brainstem auditory evoked potentials: A follow-up study. *Pediatrics* 73:22-26.
- Simmons, F., McFarland, W., and Jones, F. (1979). An automated hearing screening technique for newborns. *Acta Otolaryngol* 87:1-8.
- Stein, L.K. (1986). Follow-up of infants in a neonatal hearing screening program. In: Swigart, E.T., ed. *Neonatal Hearing Screening*. San Diego: College-Hill Press, 67-95.
- Stein, L., Clark, S., and Kraus, N. (1983). The hearing-impaired infant: Patterns of identification and habilitation. *Ear Hear* 3:232-236.
- Stevens, J.C., Webb, H.D., Hutchinson, J., Connell, J., Smith, M.F., and Buffin, J.T. (1990). Click evoked otoacoustic emissions in neonatal screening. *Ear Hear* 11:201-205.
- Swigonski, N., Shallop, J., Bull, M., and Lemons, J. (1987). Hearing screening of high risk newborns. *Ear Hear* 8:26-30.
- Turner, R. (In press). Comparison of four hearing screening protocols. *J Am Acad Audiol*. In press.
- Turner, R. (In press). Factors that determine the cost and performance of early identification protocols. *J Am Acad Audiol*. In press.
- Turner, R., Shepard, N., and Frazer, G. (1984). Formulating and evaluating audiological test protocols. *Ear Hear* 9:177-189.
- van Zanten, G.A., Brocaar, M.P., Fetter, W.P.F., and Baerts, W. (1988). Brainstem electric response audiometry in preterm infants. *Scand Audiol [Suppl]* 30:31-97.

Reprint requests: Robert G. Turner, 400 Parnassus, Room A 706, UCSF, San Francisco, CA 94143-0340